

TM

AlfrescoTM

Open Air Culinary Systems



AXE-PZA Pizza Oven **PARTS MANUAL**

BILL OF MATERIAL

NO.	PART #	DESCRIPTION	QTY
1	100-2443	ALF-PZA BUFFER PLATE	1
2	100-2456	ALF-PZA LIGHT MOUNTING PLATE	1
3	100-2470	ALF-PZA BURNER BOX HEAT SHIELD	1
4	100-2474	ALF-PZA BASE LEFT SIDE - HEAT SHIELD	1
5	100-2477	ALF-PZA BASE RIGHT SIDE - HEAT SHIELD	1
6	100-2478	ALF-PZA SMOKER BOX	1
7	100-2498	ALF-PZA PIZZA STONE BACK BRACKET	1
8	200-0057	SCREW 1/4-20 X 1/2 - TRUSS HEAD - PHILLIPS	2
9	200-0087	WASHER - 1/4" SPRING LOCK- REGULAR - SS	5
10	200-0089	BOLT - HEX HEAD 1/4-20 x 1/2" L	5
11	200-0111	SCREW 8-18 X 1/2 - SELF TAP - 410 SS	45
12	200-0348	SCREW 6-32 x 3/8-THREAD CUTTER-FLAT HEAD PHILIPS	4
13	290-0364	ALF-PZA IR BURNER	1
14	290-0365	ALF-PZA CERAMIC WOOD LOG	1
15	290-0366	ALF-PZA BOTTOM PIZZA STONE	2
16	290-0367	ALF-PZA TOP REFRACTIVE STONE	1
17	290-0377	ALFRESCO RANGE LOGO 2014	1
18	290-0388	ALFRESCO RANGE KNOB - BEZEL RING	2
19	510-0785	ALF-PZA OPENING ARCH ASSEMBLY	1
20	510-0786	ALF-PZA OVEN LINER	1
21	510-0787	ALZ-PZA TOP SKIN ASSEMBLY	1
22	510-0790	ALF-PZA TOP ASSEMBLY	1
23	510-0791	ALF/AXE-PZA LEFT DOOR ASSEMBLY	1
24	510-0795	ALF/AXE-PZA RIGHT DOOR ASSEMBLY	1
25	510-0806	ALF/AXE-PZA BURNER BOX - BOTTOM STRUCTURE	1
26	510-0818	ALF-PZA GAS LOG SUPPORT ASSEMBLY	1
27	510-1059	AXE-PZA GAS MANIFOLD ASSEMBLY	1
28	510-1062	AXE-PZA ELECTRICAL COMPONENTS	1
29	510-0939	AXE-PZA FRONT PANEL MAIN ASSEMBLY	1

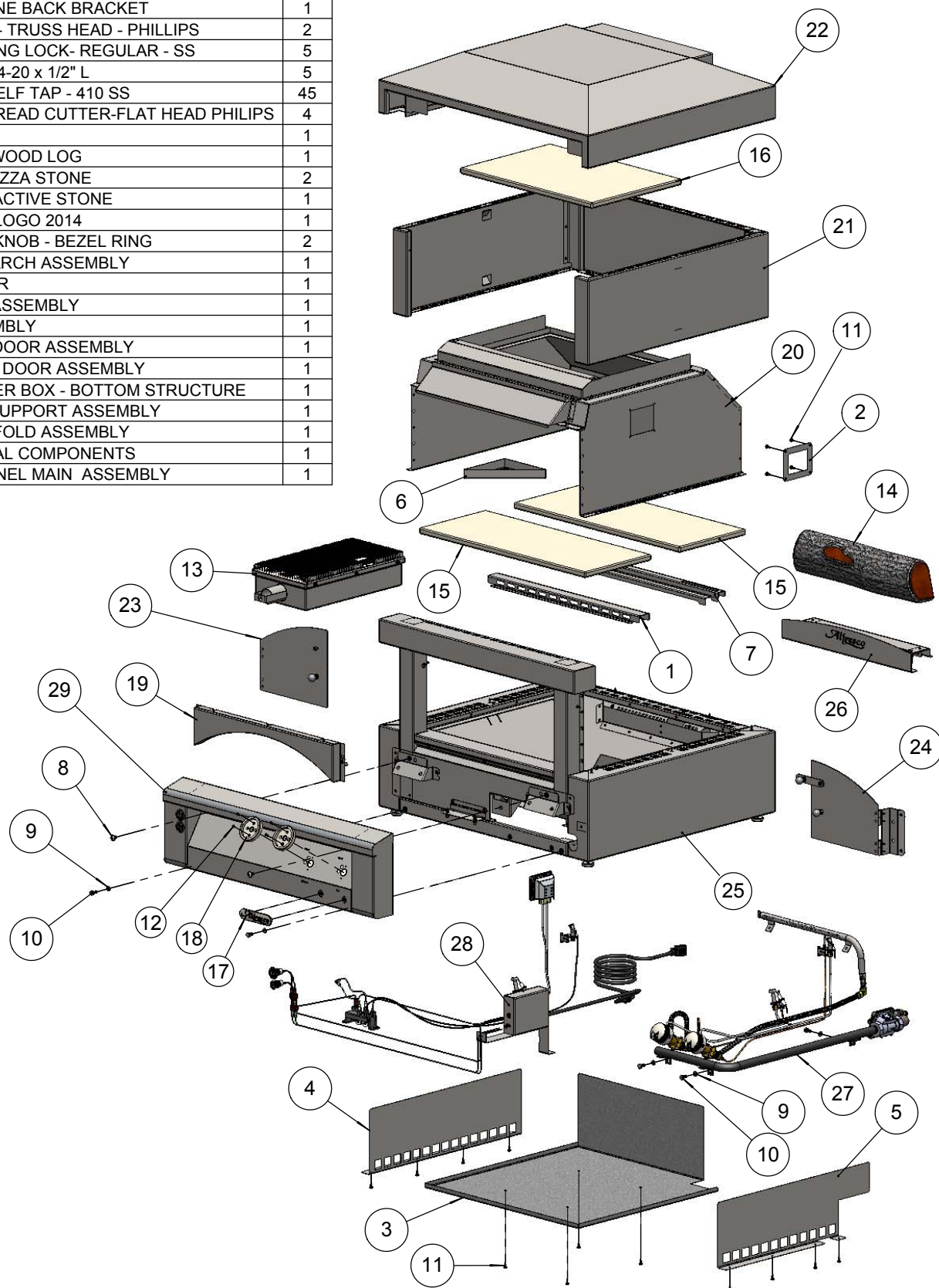

BILL OF MATERIAL

NO.	PART #	DESCRIPTION	QTY
1	100-0917	ALF/AXE-PZA IR BURNER GAS LINE - 3/8" Ø x 8" - RIBBED	1
2	100-0941	ALF/AXE-PZA LOG BURNER GAS LINE - 3/8"Ø X 24" - RIBBED	1
3	100-2484	ALF/AXE-PZA IR BURNER PILOT LIGHT - 3/16"Ø AL	1
4	100-2486	ALF/AXE-PZA LOG BURNER PILOT LINE - 3/16" Ø AL TUBE	1
5	200-0274	ELBOW 90° - CAST IRON - 1/2" FPT x 1/2" MPT	2
6	220-0275	NIPPLE - 1/2" MPT X 3/8" OD FL	1
7	220-0280	REGULATOR GAS - MAXITROL RV48CL440002	1
8	220-0293	ELBOW 3/8-27 UNS x 3/8" COMP	2
9	220-0439	ALF/AXE-PZA MANIFOLD	1
10	220-0438	COUPLING 3/8 NPTF x 3/8 COMPRESSION	2
11	220-0440	PILOT ASSEMBLY - 6210-236 B12H5 ST w/ORIFICE	1
12	220-0446	THERMOCOUPLE ASSEMBLY - 36" - 6500-011	2
13	220-0450	PILOT ASSEMBLY - 6210-420 B12H2 w/ORIFICE	1
14	290-0451	ALFRESCO - PZA - KNOB	2
15	290-0368	VALVE ABCE-W-LH - GAS W/PILOT & LOW ADJ.	2
16	290-0373	ALF/AXE-PZA BACK LOG BURNER	1
17	SEE NOTE	ALF/AXE-PZA LOG BURNER ORIFICE	1
18	SEE NOTE	ALF/AXE -PZA IR-BURNER NOZZLE ORIFICE	1

NOTE : ORIFICE FUEL SUPPLY REQUIREMENT

ITEM	NG - PART #	LP - PART #
11 & 13	220-0454	220-0442
17	220-0414	220-0415
18	220-0436	220-0437

◀ INTERNAL ORIFICES

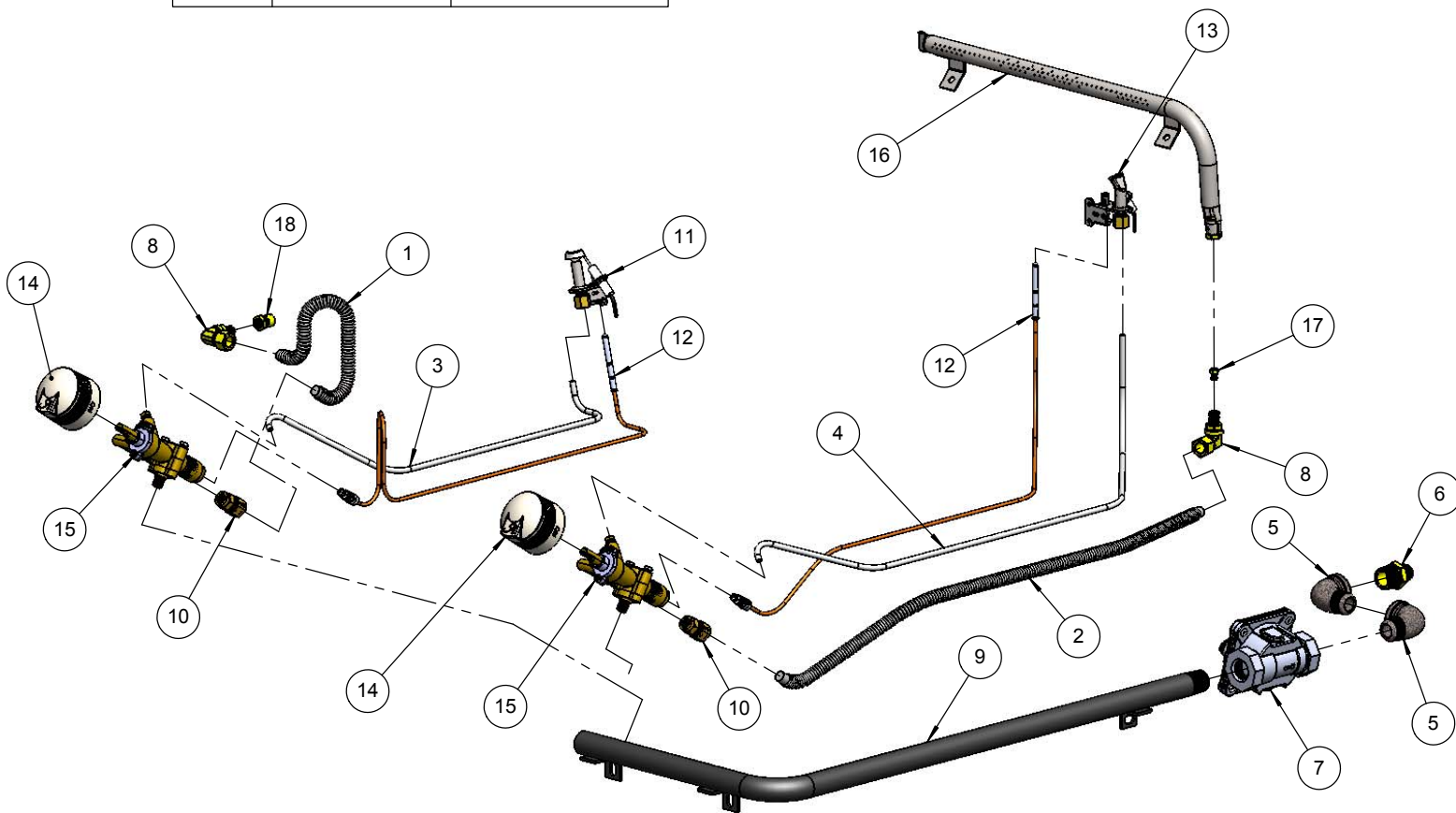

BILL OF MATERIAL

NO.	PART #	DESCRIPTION	QTY
1	200-0112	SCREW 10-32 x 1/4 x 1/8 x 1/4- SHOULDER - 1/8 SOCKET - SS	1
2	200-0238	10-32 KEP NUT 18-8 STAINLESS	1
3	200-0341	NUT WING 10-32 - SS.SLDPRT	2
4	510-0792	ALF-PZA LEFT DOOR HINGE SUBASSEMBLY	1
5	510-0793	ALF-PZA LEFT DOOR SUBASSEMBLY	1

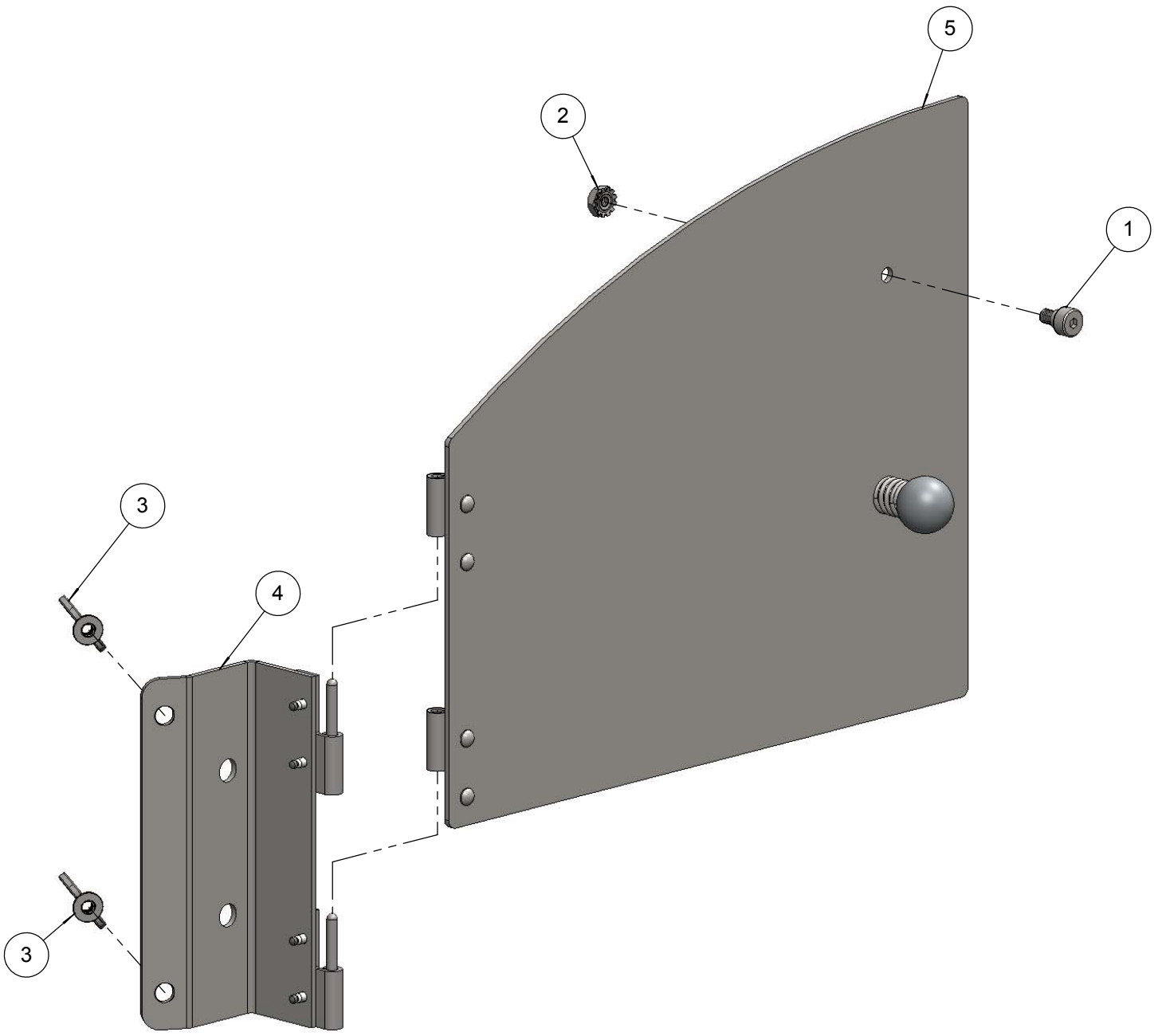

BILL OF MATERIAL			
NO.	PART #	DESCRIPTION	QTY
1	200-0112	SCREW 10-32 x 1/4 x 1/8 x 1/4- SHOULDER - 1/8 SOCKET - SS	1
2	200-0238	10-32 KEP NUT 18-8 STAINLESS	1
3	200-0244	WASHER, FLAT 1/4 TYPE B - REGULAR, SS	1
4	200-0341	NUT WING 10-32 - SS.SLDPRT	2
5	510-0794	ALF-PZA RIGHT DOOR - HINGE SUBASSEMBLY	1
6	510-0805	ALF-PZA RIGHT DOOR SUBASSEMBLY	1
7	510-0809	ALF-PZA DOOR LATCH	1

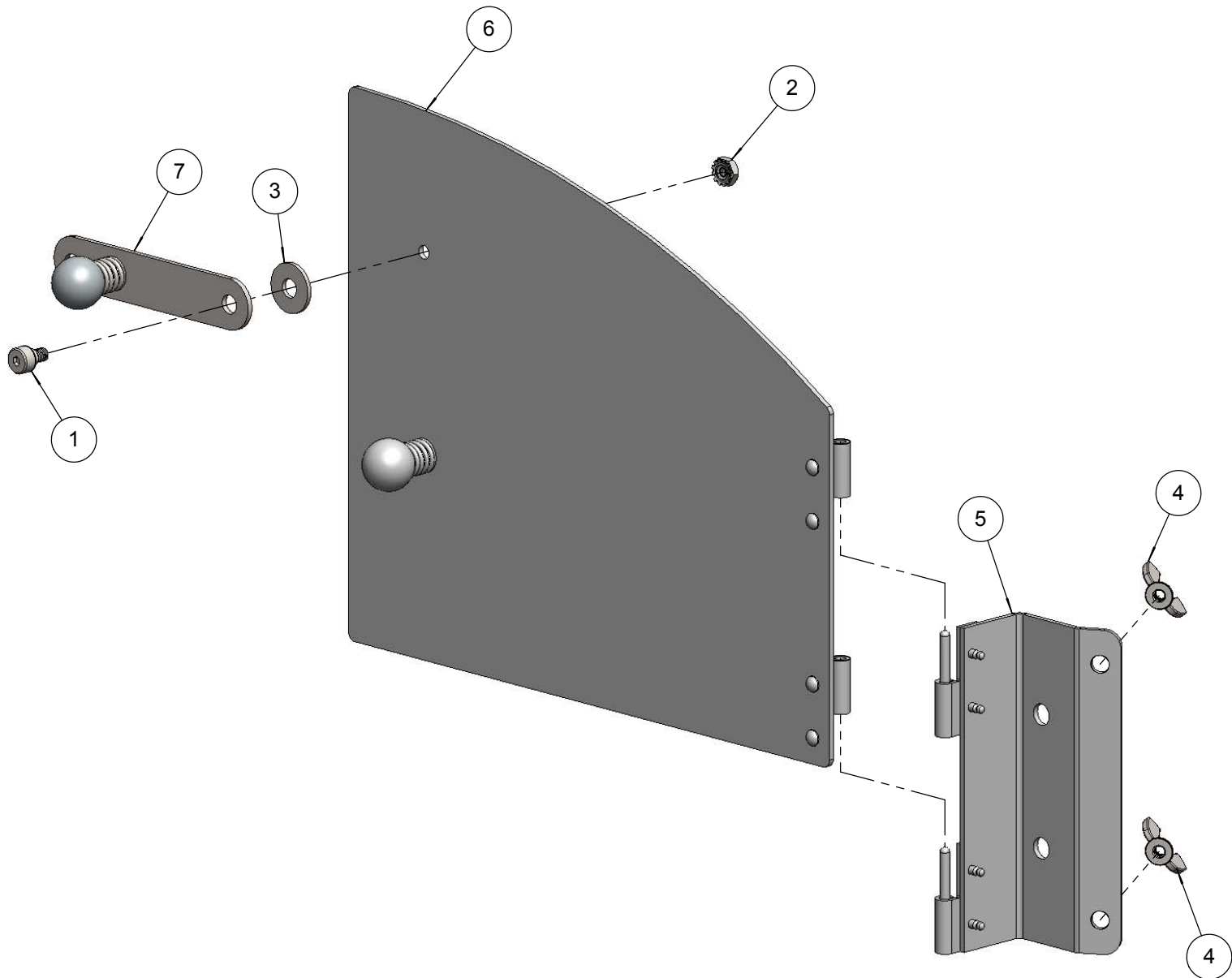

BILL OF MATERIAL

NO.	PART #	DESCRIPTION	QTY
1	100-2476	ALF-PZA ELECTRICAL BOX COVER	1
2	200-0062	10-32 X 3/4 - PAN HEAD - PHILLIPS SCREW	2
3	200-0075	WASHER - LOCK # 10 SPRING REGULAR	2
4	200-0111	SCREW 8-18 X 1/2 - SELF TAP - 410 SS	6
5	200-0267	10-32 X 1/2 - PAN HEAD - PHILLIPS SCREW	1
6	290-0362	LEVEL MOUNT 1/4-20 x 2 1/4	4
7	510-0813	ALF-PZA IGNITER BRACKET ASSEMBLY	1
8	510-0814	ALF-PZA BULLNOSE BRACKET ASSEMBLY	1
9	510-0814	ALF-PZA BULLNOSE BRACKET ASSEMBLY	1
10	510-0816	ALF-PZA BURNER BOX RIVETED PARTS	1

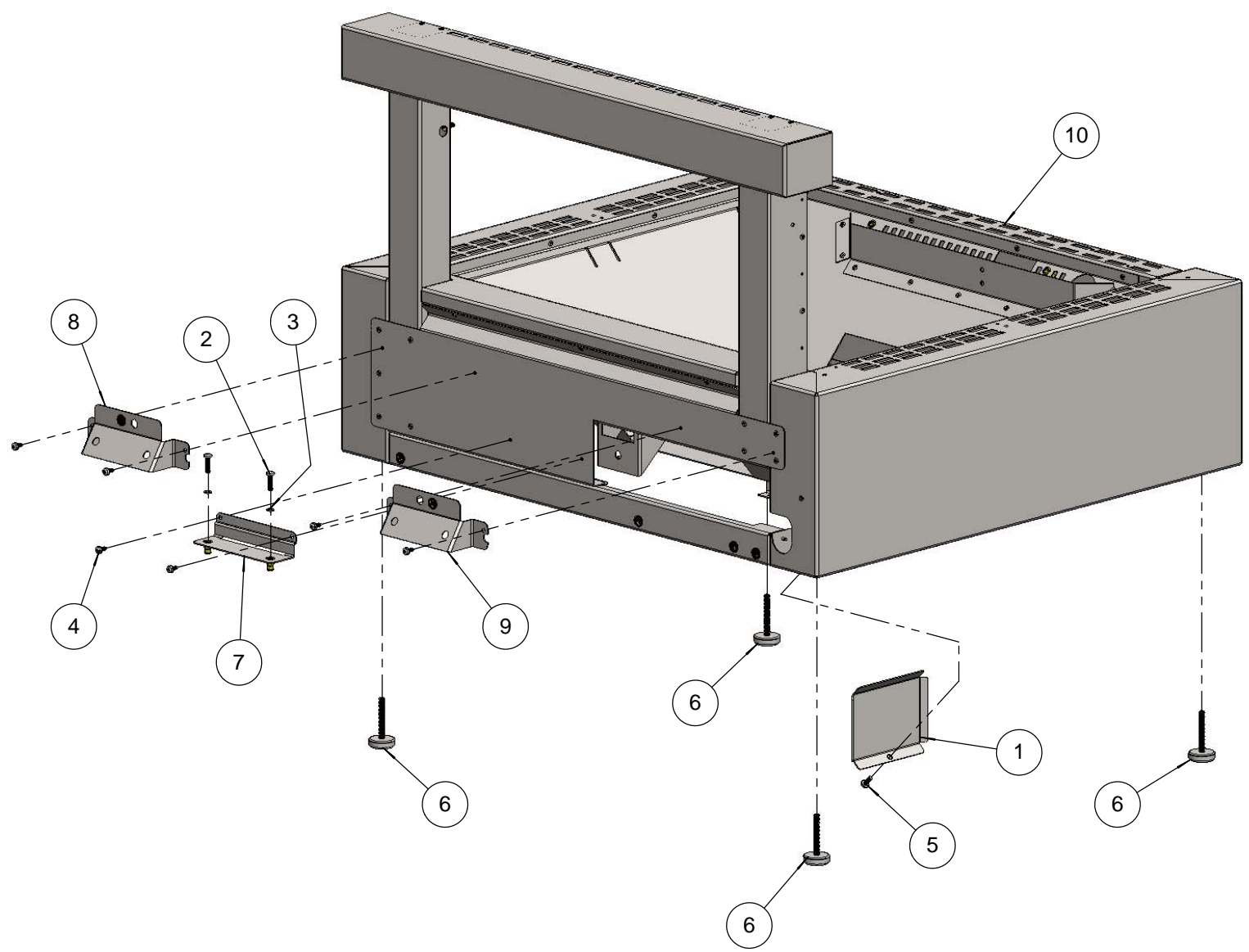

BILL OF MATERIAL

NO.	PART #	DESCRIPTION	QTY
1	200-0007	GROMMET 1/4" Ø - SRB RUBBER	2
2	200-0009	HEYCO STRESS RELIEF BUSHING # 1200 SR 6N3-4	2
3	210-0465	IGNITER MODULE (4 POINTS)	1
4	210-0488	LAMP FIXTURE ASSEMBLY - G9/120V/40W	1
5	210-0499	BLACK POWER SUPPLY CORD 125V 15A 14/3 X 8FT LONG	1
6	210-0501	IGNITER GROUNDING CABLE	1
7	210-0501	IGNITER GROUNDING CABLE	1
8	210-0583	SWITCH - IGNITION - MOMENTARY [ON]/OFF	1
9	210-0584	SWITCH - LIGHT - LATCHING [ON/OFF]	1
10	210-0646	IGNITION / LIGHT SWITCH WIRE (37")	3
11	210-0647	IGNITION SWITCH WIRE (12")	1
12	210-0648	NEUTRAL WIRE (30")	1
13	SEE NOTE 1	PILOT BODY AND ELECTRODE 6210-236 B12H5 ST	1
14	SEE NOTE 1	PILOT BODY AND ELECTRODE 6210-420 B12H2	1
15	SEE NOTE 2	ALF-PZA ELECTRICAL BOX	1

REPLACEMENT GLASS COVER
PART#210-0286

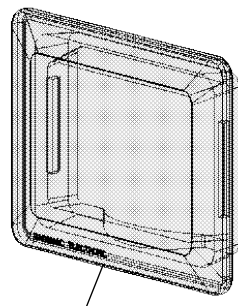

REPLACEMENT LAMP
G940120 - G9 BASE
40 W - 120 VAC
PART# 210-0317

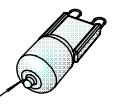

NOTE # 1:
THE PILOT IGNITER ELECTRODES SHOWN ARE FOR ILLUSTRATION ONLY.
THE COMPONENT PART NUMBERS ARE SHOWN ON PIPING DIAGRAM.
THE ASSEMBLIES CONSISTS OF PIPING COMPONENTS ,IGNITERS AND WIRING.

NOTE # 2:
ELECTRICAL BOX SHOWN FOR ILLUSTRATION ONLY.
ELECTRICAL BOX IS PART OF BURNER BOX ASSEMBLY 510-0806.

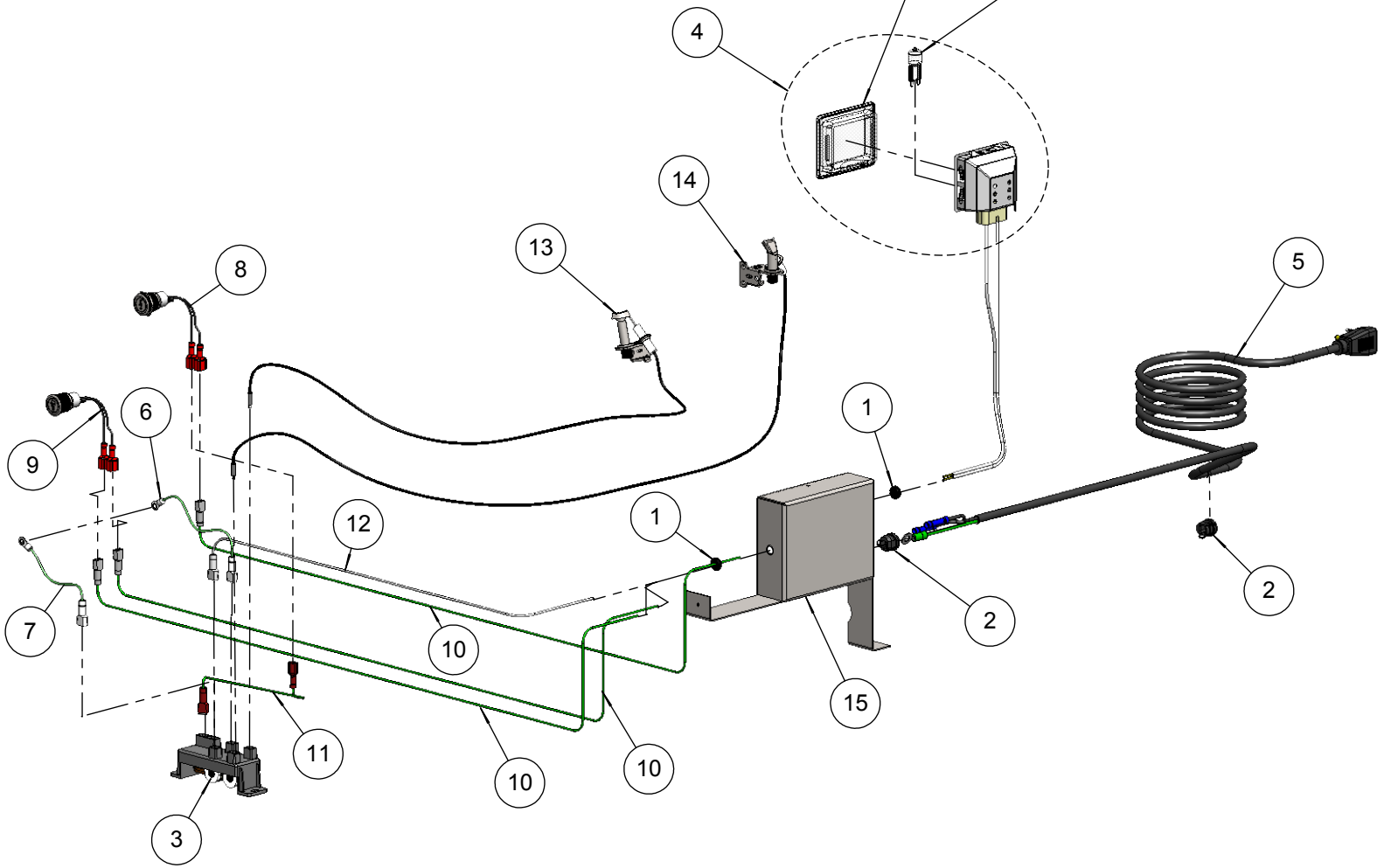

TM

*Alfresco*TM

Open Air Culinary Systems

AXE-PZA PARTS MANUAL
ALFRESCO GOURMET GRILLS
ALL RIGHTS RESERVED 07/08/16